

# Eyre Seat

1

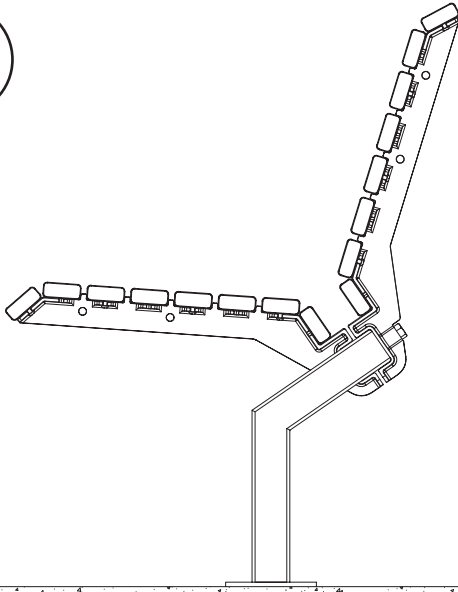

- Position seat
- Mark 4x hole centres through mounting holes

2

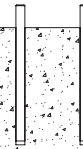

- Use hammer drill with 12mm masonry bit to drill marked holes minimum depth 155mm
- Clear holes with wire brush or compressed air
- Fill holes with chemset epoxy
- Insert M12 x 180mm threaded anchor bolt into each hole. Ensure between 25mm and 30mm of each anchor bolt protrudes above mounting surface
- Allow chemset epoxy to set according to manufacturer's instructions

# Eyre Seat

3

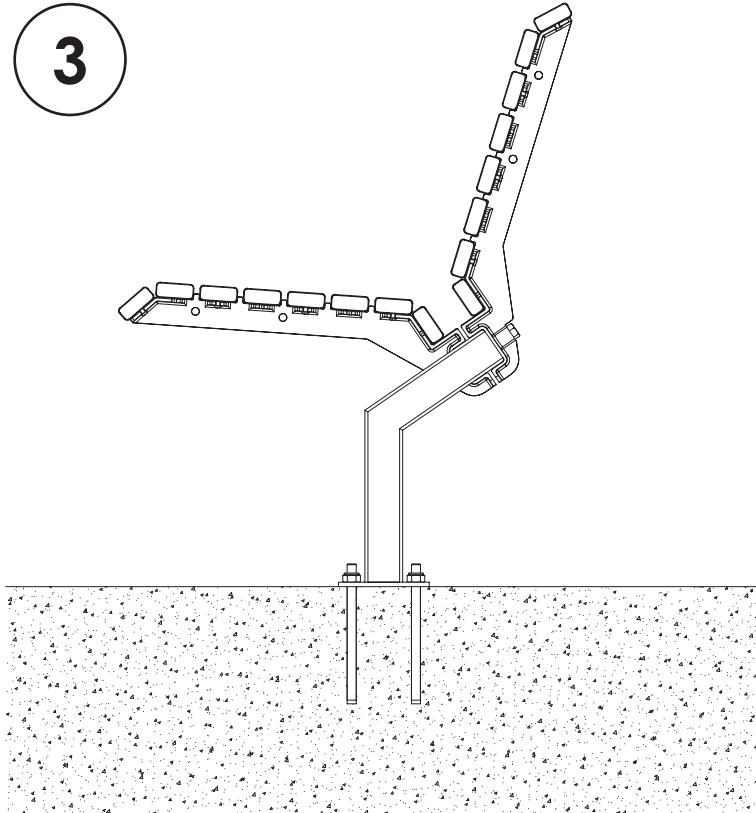

- Place seat onto anchor bolts
- Thread 1x M12 washer and 1x M12 nylock nut onto each anchor bolt
- Use socket wrench to tighten M12 nylock nuts securely onto each anchor bolt

Note:

- All tools and installation fixings to be supplied by contractor
- Footing design to be determined by site engineer based on local conditions
- For higher security option, use M12 shear nuts in place of M12 nylock nuts

# Eyre Seat

1

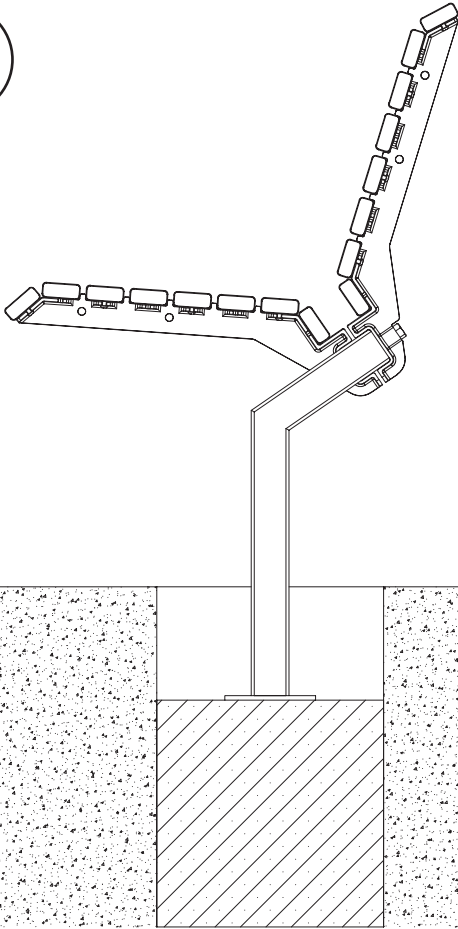

- Position seat
- Mark 4x hole centres through mounting holes

2

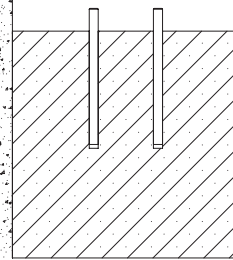

- Use hammer drill with 12mm masonry bit to drill marked holes minimum depth 155mm
- Clear holes with wire brush or compressed air
- Fill holes with chemset epoxy
- Insert M12 x 180mm threaded anchor bolt into each hole. Ensure between 25mm and 30mm of each anchor bolt protrudes above mounting surface
- Allow chemset epoxy to set according to manufacturer's instructions

# Eyre Seat

3

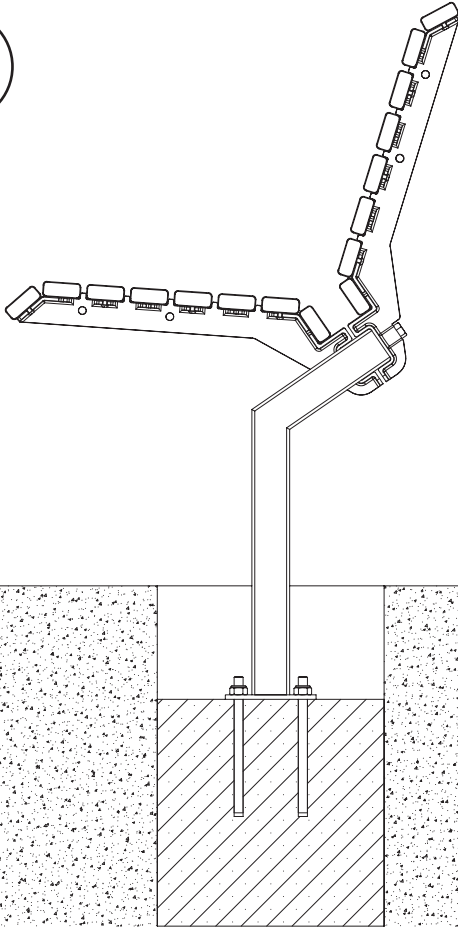

- Place seat onto anchor bolts
- Thread 1x M12 washer and 1x M12 nylock nut onto each anchor bolt
- Use socket wrench to tighten M12 nylock nuts securely onto each anchor bolt

4

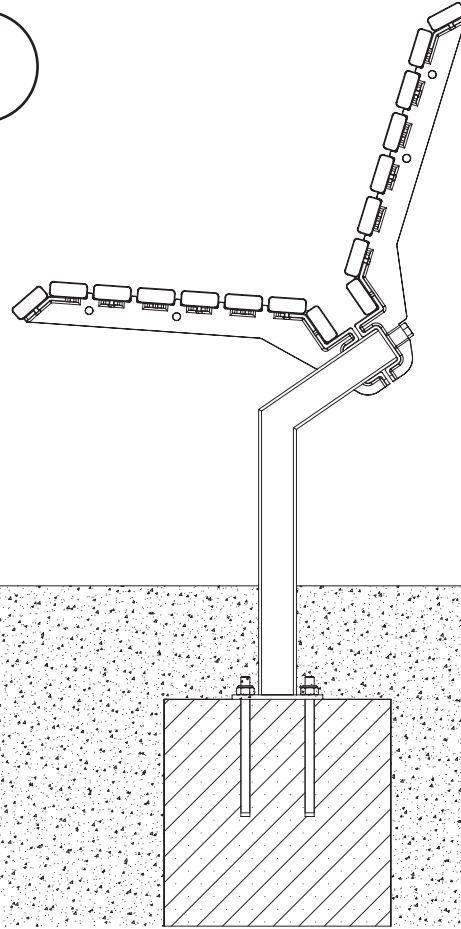

- Backfill or pave to FGL

Note:

- All tools and installation fixings to be supplied by contractor
- Footing to be set with mounting surface at 150mm below FGL
- Footing design to be determined by site engineer based on local conditions
- Mos recommends minimum 2x pier footings 300mm x 300mm x 500mm positioned 1750mm between footing centres